

WIR MACHEN
LÖCHER

seit 1883
DAPPRICH
Präzisionswerkzeuge



WUPPERTAL

SITEH3RO™

ROTABROACH.CO.UK

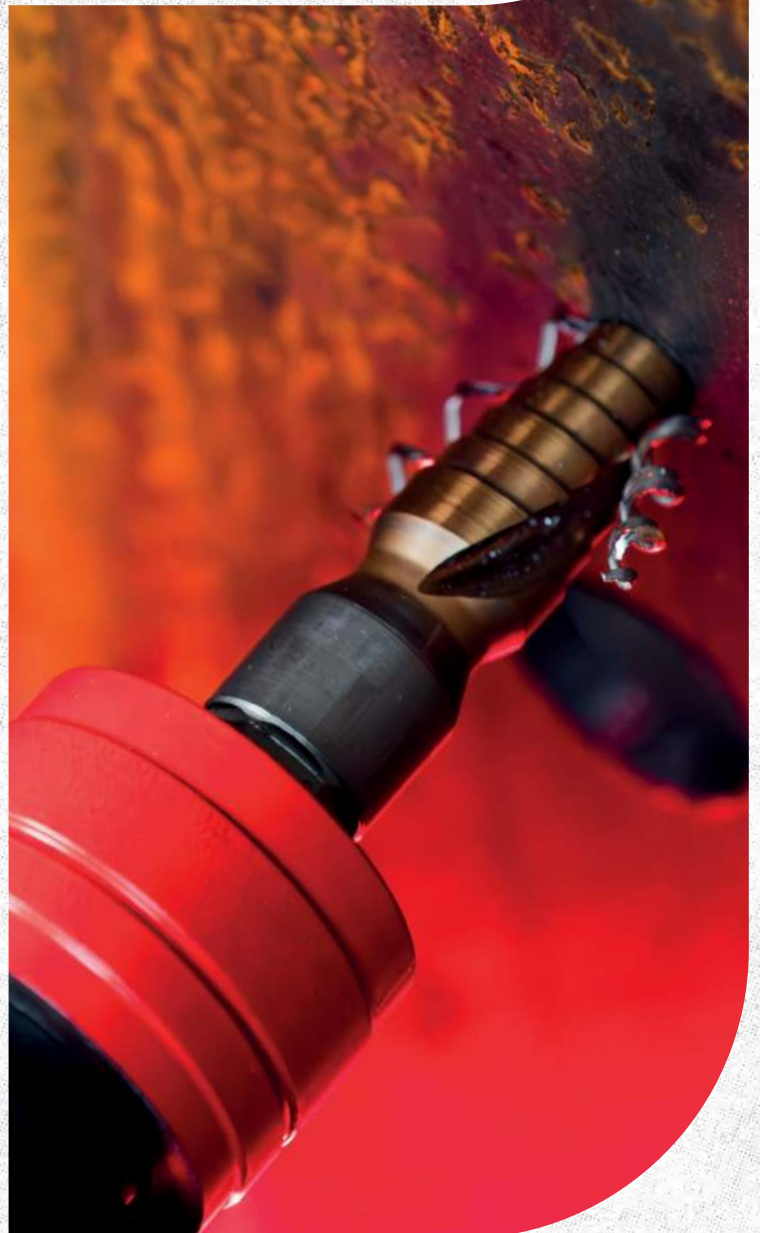
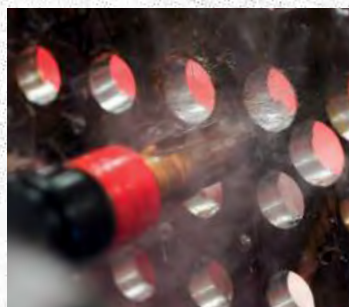

R

SITEH3RO™

SITEH3RO™

*Verwandle Deinen
Schlagschrauber in eine
Multi-Funktions-Maschine !*



Int. Pat. Pending. WO2024/100390



ROTABROACH.CO.UK

Verbinden Klick **GO**

Verwandle Deinen Schlagschrauber in eine Multi-Funktions-Maschine!

1. Verbinden

Connect the holder to the Impact Wrench

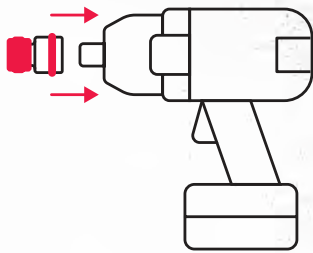

2. Click

Insert the tool

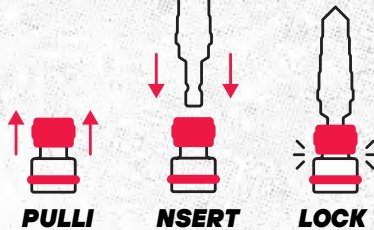
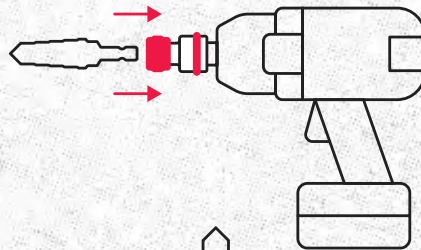

3. GO

Start DRILLING!

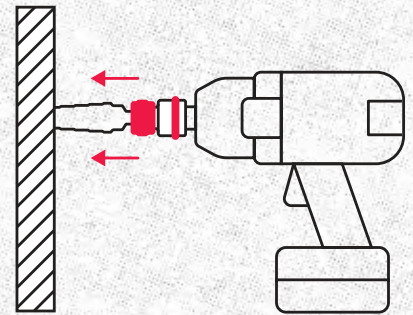

Drill new, expand, thread and align holes for the major diameters

SMOOTH, EASY CUT

75%
Longer life with SITEH3RO™ coating

Suitable for 1/2" and 3/4" Impact Wrenches (holder dependent)

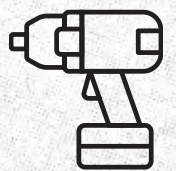

Make **NEW HOLES** with Step Drills & Step Reamers



ALIGN HOLES with Car Reamers



THREAD HOLES with Taps



EXPAND HOLES with Step Drills and Step & Car Reamers

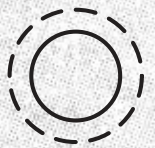

SITEH3RO™: Holder

SITEH3RO™

SITEH3RO™ HOLDER

Int. Pat. Pending. WO2024/100390

High Temperature Tested to 180°C



Quick Release

Suitable for 1/2" and 3/4" Impact Wrenches

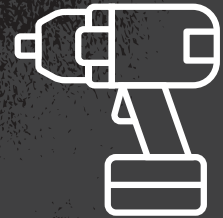

SITEH3RO™ Holder Sizes:

Part Number	Description	Size	Impact Wrench
RSH12	1/2" Square Holder	1/2"	1/2" Impact Wrench
RSH34	3/4" Square Holder	3/4"	3/4" Impact Wrench

Turn your Impact Wrench into a multipurpose metal working machine.

1. Connect

Connect the holder to the Impact Wrench

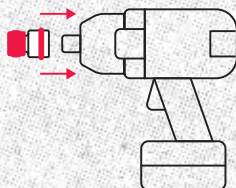

2. Click

Insert the tool

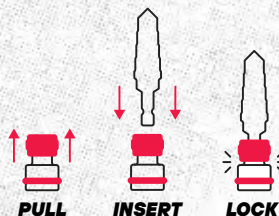
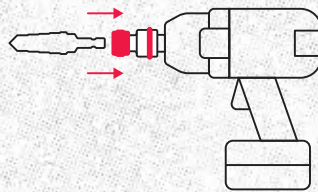

3. GO

Start DRILLING!

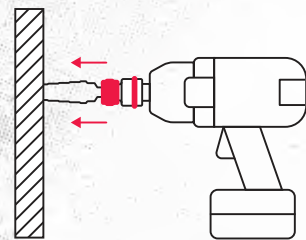

SITEH3RO™: Car Reamer

SITEH3RO™

CAR REAMER



- Align, clean out and expand holes on site with your Impact Wrench and SITEH3RO™
- High performance coating for up to 75% longer tool life
- Available in 18 major diameter sizes
- Suitable for use in standard 3-jaw drill chucks
- Smooth, easy cut

CAR REAMER Sizes:

Part Number	Diameter	Shank
CR08	8mm	7/16" Hex Impact Shank
CR10	10mm	
CR11	11mm	
CR12	12mm	
CR13	13mm	
CR14	14mm	
CR15	15mm	
CR16	16mm	
CR17	17mm	
CR18	18mm	
CR19	19mm	
CR20	20mm	
CR21	21mm	
CR22	22mm	
CR23	23mm	
CR24	24mm	
CR25	25mm	
CR26	26mm	

CAR REAMER Kits:

Part Number	Size Range	Kit Description
SHRCR1	14, 18, 22mm	3 Piece Kit
SHRCR2	12, 14, 18, 22 & 26mm	5 Piece Kit
SHRCR3	8, 10, 12, 14, 16, 18, 20, 22, 24, 26mm	10 Piece Kit

75%

Longer life with SITEH3RO™ coating

Suitable for 1/2" and 3/4" Impact Wrenches (holder dependent)

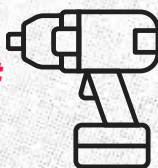

ALIGN HOLES

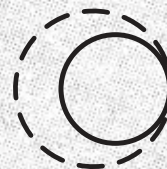

EXPAND HOLES



SITEH3RO™: Step Reamer

SITEH3RO™

STEP REAMER

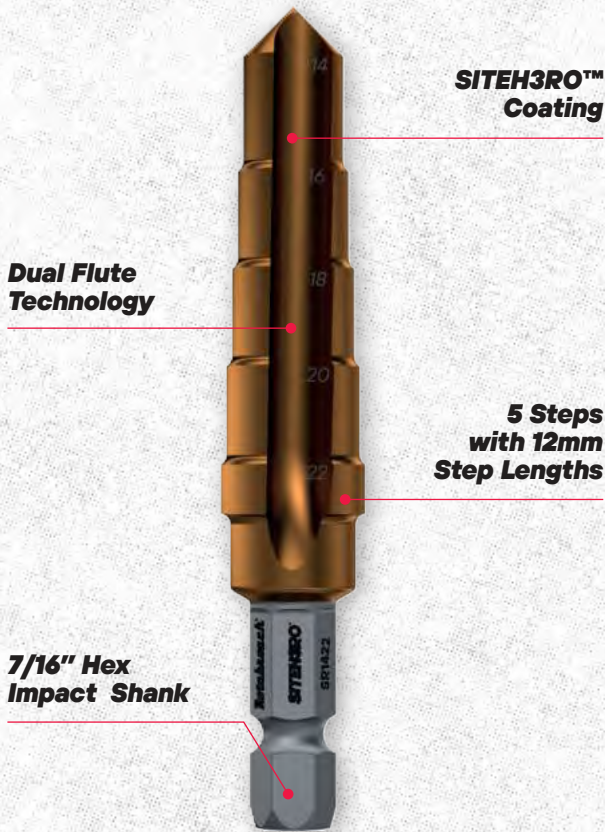

- Expand and clean out holes with your Impact Wrench
- 3 tools allow you to expand and clean out holes across 15 sizes from 8mm to 28mm in up to 12mm thick material
- Ideal for expanding holes and available in all major bolt sizes
- High performance coating, providing up to 75% longer tool life
- Suitable for use in standard 3-jaw drill chucks

STEP REAMER Sizes:

Part Number	Diameter	Shank
SR816	8mm to 16mm	7/16" Hex Impact Shank
SR1422	14mm to 22mm	
SR2028	20mm to 28mm	

All STEP REAMERS include 5 steps with 12mm Step Lengths.

STEP REAMER Kit:

Part Number	Diameter	Shank
SHRSR1	8mm to 16mm 14mm to 22mm 20mm to 28mm	7/16" Hex Impact Shank

75%
Longer life with
SITEH3RO™ coating

Suitable for
1/2" and
3/4" Impact
Wrenches
(holder
dependent)

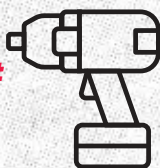

NEW HOLES

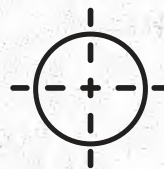

EXPAND HOLES



SITEH3RO™: Step Drill

SITEH3RO™

STEP DRILL

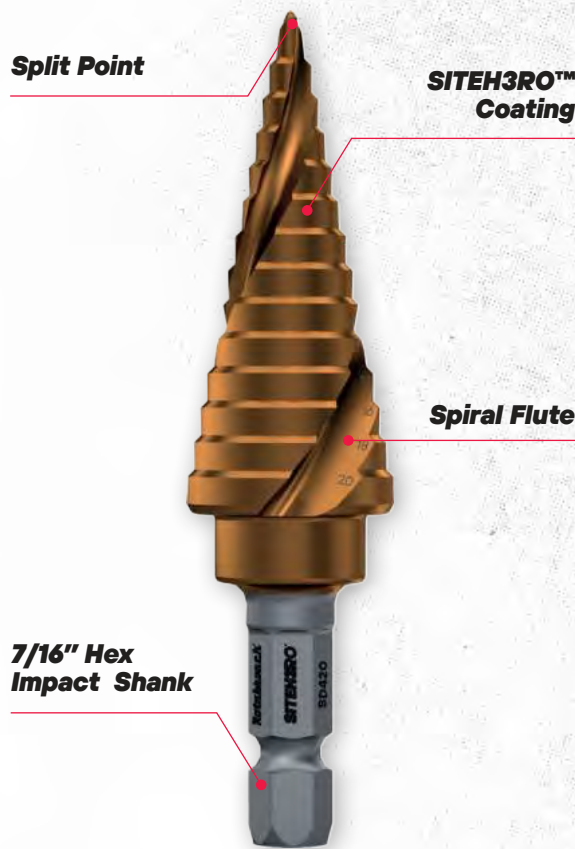

- Drill new holes and expand thin gauge material with an Impact Wrench and SITEH3RO™
- Utilise in SITEH3RO™ holders for Impact Wrenches or any standard drill chuck
- Holes from 4mm to 30mm in diameter, each step 5mm
- High performance coating for up to 75% longer tool life
- Suitable for use in standard 3-jaw drill chucks

STEP DRILL Sizes:

Part Number	Diameter	Shank
SD412	4mm to 12mm	7/16" Hex Impact Shank
SD420	4mm to 20mm	
SD430	4mm to 30mm	

All STEP DRILLS include a spiral flute with a 118° point.

STEP DRILL Kit:

Part Number	Diameter	Shank
SHRSD1	4mm to 12mm 4mm to 20mm 4mm to 30mm	7/16" Hex Impact Shank

75%
Longer life with SITEH3RO™ coating

Suitable for 1/2" and 3/4" Impact Wrenches (holder dependent)

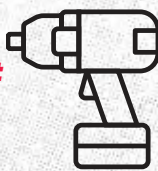

NEW HOLES

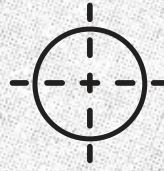

EXPAND HOLES

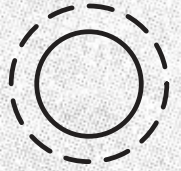

SITEH3RO™: Taps

SITEH3RO™

TAPS

Spiral Point Machine Tap



SITEH3RO™ Coating

7/16" Hex Impact Shank

- **Spiral Point Machine Tap : One Tap Solution**
- **Thread holes with your Impact Wrench – up to 20 X faster than hand tapping**
- **High performance coating for up to 75% longer tool life**
- **Thread holes from M5 to M30**
- **Tap holes in material up to 25mm deep**
- **Available in 12 major sizes**

TAP Sizes:

Part Number	Diameter	Shank
TPM5	M5 x 0.80	7/16" Hex Impact Shank
TPM6	M6 x 1.00	
TPM8	M8 x 1.25	
TPM10	M10 x 1.50	
TPM12	M12 x 1.75	
TPM14	M14 x 2.00	
TPM16	M16 x 2.00	
TPM18	M18 x 2.50	
TPM20	M20 x 2.50	
TPM24	M24 x 3.00	
TPM27	M27 x 3.00	
TPM30	M30 x 3.50	

TAP Kits:

Part Number	Diameter	Kit
SHRTP1	M6, M8, M10, M12, M16	5 Piece Kit
SHRTP2	M12, M16, M20, M24	4 Piece Kit
SHRTP3	M5, M6, M8, M10, M12, M14, M16, M18, M20, M24, M27, M30	12 Piece Kit

75%

Longer life with SITEH3RO™ coating

Suitable for 1/2" and 3/4" Impact Wrenches (holder dependent)

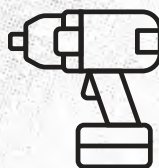

THREAD HOLES



SITEH3RO™: Kits

SITEH3RO™

KITS



- **Align, Thread, Expand and Drill New Holes**
- **SITEH3RO™ kit solutions for all major applications**
- **Multiple kit sizes available per tool type**

SITEH3RO™ Ultimate Kit:

Part Number	Tool Type	Diameter	Qty
SHR1	Step Drills	4-12mm / 4-20mm / 4-30mm	3
	Step Reamers	8-16mm / 14-22mm / 20-28mm	3
	Taps	M6, M8, M10 & M12	4
	Car Reamers	14mm / 18mm & 22mm	3
	Holder	1/2" & 3/4"	2

CAR REAMER Kits:

Part Number	Size Range	Kit Description
SHRCR1	14, 18, 22mm	3 Piece Kit
SHRCR2	12, 14, 18, 22 & 26mm	5 Piece Kit
SHRCR3	8, 10, 12, 14, 16, 18, 20, 22, 24, 26mm	10 Piece Kit

STEP REAMER Kit:

Part Number	Diameter	Shank
SHRSR1	8mm to 16mm 14mm to 22mm 20mm to 28mm	7/16" Hex Impact Shank

STEP DRILL Kit:

Part Number	Diameter	Shank
SHRSD1	4mm to 12mm 4mm to 20mm 4mm to 30mm	7/16" Hex Impact Shank

TAP Kits:

Part Number	Diameter	Kit
SHRTP1	M6, M8, M10, M12, M16	5 Piece Kit
SHRTP2	M12, M16, M20, M24	4 Piece Kit
SHRTP3	M5, M6, M8, M10, M12, M14, M16, M18, M20, M24, M27, M30	12 Piece Kit

75%

Longer life with SITEH3RO™ coating

Suitable for 1/2" and 3/4" Impact Wrenches (holder dependent)

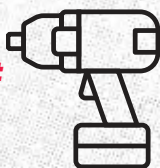

NEW HOLES



EXPAND HOLES



THREAD HOLES



ALIGN HOLES

POWER To Cut Metal.





Rotabroach

POWER To Cut Metal.

SITEH3RO™

15 PIECE SET

- 2 X SITEHERO HOLDERS - 1/2" & 3/4"
- 3 X STEP DRILLS - 4-12mm, 4-20mm, 4-30mm
- 3 X CAR REAMERS - 14mm, 18mm, 22mm
- 3 X STEP REAMERS - 8-16mm, 14-22mm, 20-28mm
- 4 X TAPS - M6, M8, M10, M12

Drill new,
expand, thread
and align holes
for the major
diameters

75%
Longer life
with SITEH3RO
coating

**SMOOTH,
EASY CUT**



Suitable for 1/2"
and 3/4" Impact
Wrenches*

*Metric dependent



STEP
DRILLS

STEP
REAMERS

CAR
REAMERS

TAPS

Make **NEW HOLES**
with Step Drills
& Step Reamers

ALIGN HOLES
with Car Reamers

THREAD HOLES
with Taps

EXPAND HOLES
with Step Drills and
Step & Car Reamers



**Turn your Impact Wrench
into a multipurpose
metal working machine.
Connect Click GO**

POWER To Cut Metal.™

Rotabroach™

BURGESS ROAD, SHEFFIELD S9 3WD

TEL: +44 (0)114 221 2510

EMAIL: SALES@OSLCT.CO.UK

WEB: ROTABROACH.CO.UK

ROTABROACH.CO.UK



SITEH3RO™



Rotabroach

Werkzeuge für den Einsatz auf Schlagschraubern

SITEH3RO™

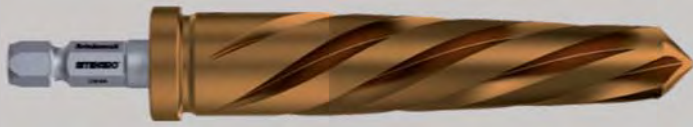

CAR-REAMER

Zum Aufweiten und Ausrichten vorhandener Bohrungen

Type	Bestell-Nummer	Ø mm	Sechskant-Schaft
CR08	72079.0800	8	7/16" (Ø11,11mm)
CR10	72079.1000	10	7/16" (Ø11,11mm)
CR11	72079.1100	11	7/16" (Ø11,11mm)
CR12	72079.1200	12	7/16" (Ø11,11mm)
CR13	72079.1300	13	7/16" (Ø11,11mm)
CR14	72079.1400	14	7/16" (Ø11,11mm)
CR15	72079.1500	15	7/16" (Ø11,11mm)
CR16	72079.1600	16	7/16" (Ø11,11mm)
CR17	72079.1700	17	7/16" (Ø11,11mm)
CR18	72079.1800	18	7/16" (Ø11,11mm)
CR19	72079.1900	19	7/16" (Ø11,11mm)
CR20	72079.2000	20	7/16" (Ø11,11mm)
CR21	72079.2100	21	7/16" (Ø11,11mm)
CR22	72079.2200	22	7/16" (Ø11,11mm)
CR23	72079.2300	23	7/16" (Ø11,11mm)
CR24	72079.2400	24	7/16" (Ø11,11mm)
CR25	72079.2500	25	7/16" (Ø11,11mm)
CR26	72079.2600	26	7/16" (Ø11,11mm)
SHRCR1	72079.1422	14-18-22	7/16" (Ø11,11mm)
SHRCR2	72079.1226	12-14-18-22-26	7/16" (Ø11,11mm)
SHRCR3	72079.0826	8-10-12-14-16-18-20-22-24-26	7/16" (Ø11,11mm)



STUFEN-BOHR-REIBAHLE

- Zum Aufweiten vorhandener Bohrungen
- Bohren neuer Löcher

Type	Bestell-Nummer	Ø mm	Sechskant-Schaft
SR816	49249.0816	8-10-12-14-16	7/16" (Ø11,11mm)
SR1422	49249.1422	14-16-18-20-22	7/16" (Ø11,11mm)
SR2028	49249.2028	20-22-24-26-28	7/16" (Ø11,11mm)
SHRSR1	49249.0828	3er Set 8-28	7/16" (Ø11,11mm)



SITEH3RO™

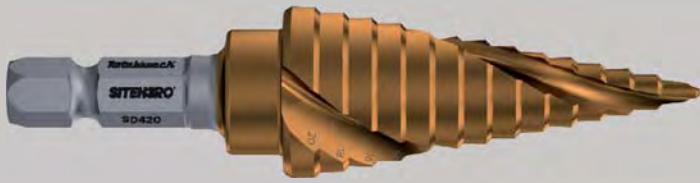

STUFENBOHR

- Zum Aufweiten vorhandener Bohrungen
- Bohren neuer Löcher

Type	Bestell-Nummer	Ø mm	Sechskant-Schaft
SD412	08139.4121	4-5-6-7-8-9-10-11-12	7/16" (Ø11,1mm)
SD420	08139.4202	4-6-8-10-12-14-16-18-20	7/16" (Ø11,1mm)
SD430	08139.4302	4-6-8-10-12-14-16-18-20-22-24-26-28-30	7/16" (Ø11,1mm)
SHRSD1	08139.0430	3er Set 4-30	7/16" (Ø11,1mm)



GEWINDEBOHRER

Für Durchgangsbohrungen bis 25 mm Materialstärke

Type	Bestell-Nummer	Ø mm	Sechskant-Schaft
TPM05	61919.050	M 5	7/16" (Ø11,1mm)
TPM06	61919.060	M 6	7/16" (Ø11,1mm)
TPM08	61919.080	M 8	7/16" (Ø11,1mm)
TPM10	61919.100	M 10	7/16" (Ø11,1mm)
TPM12	61919.120	M 12	7/16" (Ø11,1mm)
TPM14	61919.140	M 14	7/16" (Ø11,1mm)
TPM16	61919.160	M 16	7/16" (Ø11,1mm)
TPM18	61919.180	M 18	7/16" (Ø11,1mm)
TPM20	61919.200	M 20	7/16" (Ø11,1mm)
TPM24	61919.240	M 24	7/16" (Ø11,1mm)
TPM27	61919.270	M 27	7/16" (Ø11,1mm)
TPM30	61919.300	M 30	7/16" (Ø11,1mm)
SHRTP1	61919.0616	M6-8-10-12-16	7/16" (Ø11,1mm)
SHRTP2	61919.1224	M12-16-20-24	7/16" (Ø11,1mm)
SHRTP3	61919.0530	M5-6-8-10-12-14-16-18-20-24-27-30	7/16" (Ø11,1mm)



Adapter

Schnittstelle zwischen Schlagschrauber und SITEH3RO™-Werkzeugen

Type	Bestell-Nummer	Aufnahme Maschinenseite	Aufnahme Werkzeugseite
RSH12	49316.12716	1/2" IMPACT	7/16" (Ø11,1mm)
RSH34	49316.34716	3/4" IMPACT	7/16" (Ø11,1mm)



SITEH3RO™

Sets



Type	Bestell-Nummer	Werkzeug-Type	Ø mm	Anzahl Werkzeuge	Sechskant-Schaft
SHRCR1	72079.1422	Car-Reamer	14-18-22	3	7/16" (Ø11,11mm)
SHRCR2	72079.1226		12-14-18-22-26	5	7/16" (Ø11,11mm)
SHRCR3	7209.0826		8-10-12-14-16-18-20-22-24-26	10	7/16" (Ø11,11mm)
SHRSR1	49249.0828	Stufen-Bohr-Reibahle	8-10-12-14-16-14-16-18-20-22-20-22-24-26-28	3	7/16" (Ø11,11mm)
SHRSD1	08139.0430	Stufenbohrer	4-5-6-7-8-9-10-11-12-4-6-8-10-12-14-16-18-20-4-6-8-10-12-14-16-18-20-22-24-26-28-30	3	7/16" (Ø11,11mm)
SHRTP1	61919.0616	Gewindebohrer	M6-8-10-12-16	5	7/16" (Ø11,11mm)
SHRTP2	61919.1224		M12-16-20-24	4	7/16" (Ø11,11mm)
SHRTP3	61919.0530		M5-6-8-10-12-14-16-18-20-24-27-30	12	7/16" (Ø11,11mm)
SHR1	49316.3810	Ultimate-Kit		15	7/16" (Ø11,11mm)
		Car-Reamer	14-18-22		
		Stufen-Bohr-Reibahle	8-16 / 14-22 / 20x28		
		Stufenbohrer	4-12 / 4-20 / 4-30		
		Gewindebohrer	M6-8-10-12		
		Adapter	1/2" & 3/4"		